

Clack Order No. V3007-01

Description: WS1 Fitting 3/4" & 1" PVC Solvent 90° ASY

Drawing No.	Order No.	Description	Quantity
1	V3151	WS1 Nut 1" Quick Connect	2
2	V3150	WS1 Split Ring	2
3	V3105	O-Ring 215	2
4	V3189	WS1 Fitting 3/4" & 1" PVC Solvent 90	2

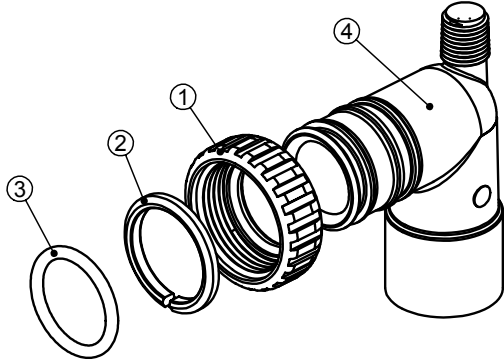

Form No. V3115-03 • 9/21/2021

Clack Order No. V3007-01

Description: WS1 Fitting 3/4" & 1" PVC Solvent 90° ASY

Drawing No.	Order No.	Description	Quantity
1	V3151	WS1 Nut 1" Quick Connect	2
2	V3150	WS1 Split Ring	2
3	V3105	O-Ring 215	2
4	V3189	WS1 Fitting 3/4" & 1" PVC Solvent 90	2

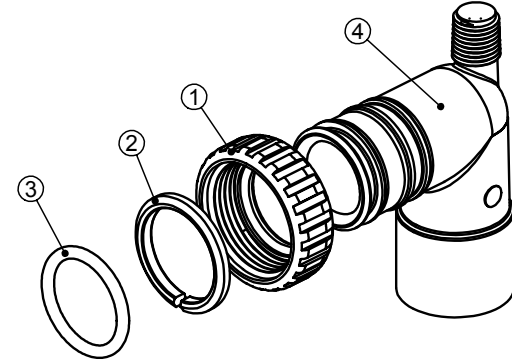

Form No. V3115-03 • 9/21/2021

Clack Order No. V3007-01

Description: WS1 Fitting 3/4" & 1" PVC Solvent 90° ASY

Drawing No.	Order No.	Description	Quantity
1	V3151	WS1 Nut 1" Quick Connect	2
2	V3150	WS1 Split Ring	2
3	V3105	O-Ring 215	2
4	V3189	WS1 Fitting 3/4" & 1" PVC Solvent 90	2

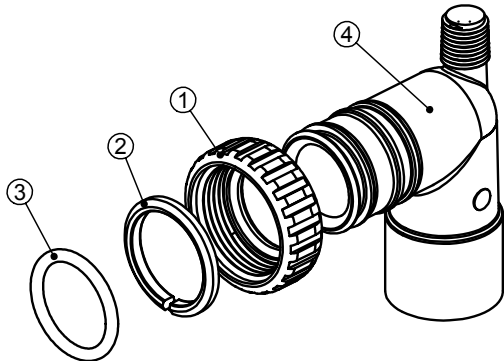

Form No. V3115-03 • 9/21/2021

Clack Order No. V3007-01

Description: WS1 Fitting 3/4" & 1" PVC Solvent 90° ASY

Drawing No.	Order No.	Description	Quantity
1	V3151	WS1 Nut 1" Quick Connect	2
2	V3150	WS1 Split Ring	2
3	V3105	O-Ring 215	2
4	V3189	WS1 Fitting 3/4" & 1" PVC Solvent 90	2

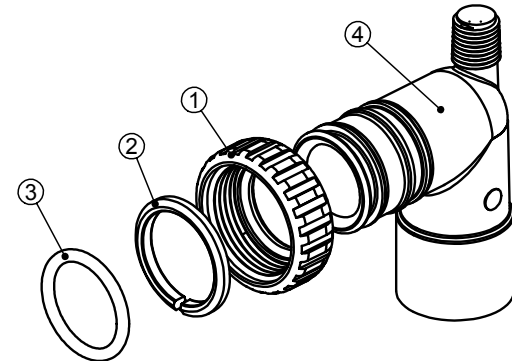

Form No. V3115-03 • 9/21/2021

Clack Order No. V3007-01

Description: WS1 Fitting 3/4" & 1" PVC Solvent 90° ASY

HYDROCARBONS SUCH AS VASELINE®, PETROLEUM JELLY, KEROSENE, BENZENE, GASOLINE, ETC., WILL DAMAGE PRODUCTS THAT CONTAIN O-RINGS OR PLASTIC COMPONENTS. EXPOSURE TO SUCH HYDROCARBONS MAY CAUSE THE PRODUCTS TO LEAK. DO NOT USE CLACK CONTROL VALVE PRODUCT(S) ON WATER SUPPLIES THAT CONTAIN HYDROCARBONS SUCH AS KEROSENE, BENZENE, GASOLINE, ETC.

Fitting Installation Instructions

- Installation fittings are designed to accommodate minor plumbing misalignments, but are not designed to support the weight of a system or the plumbing.
- Teflon tape must be used on the 1/4" NPT connection (when used).
- Avoid getting solvent cement or primer on the control valve, bypass valve, nut, split ring and o-ring.
- Use solvent cements and primers to connect fittings and piping in accordance with manufacturer's instructions.
- Allow solvent cements to set before installing the nut, split ring and o-ring.
- Slide nut on first, then the split ring and o-ring.
- Hand tighten the nut only.

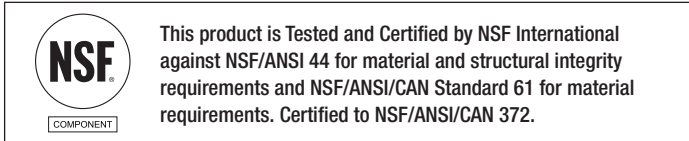

Form No. V3115-03 • 9/21/2021

Clack Order No. V3007-01

Description: WS1 Fitting 3/4" & 1" PVC Solvent 90° ASY

HYDROCARBONS SUCH AS VASELINE®, PETROLEUM JELLY, KEROSENE, BENZENE, GASOLINE, ETC., WILL DAMAGE PRODUCTS THAT CONTAIN O-RINGS OR PLASTIC COMPONENTS. EXPOSURE TO SUCH HYDROCARBONS MAY CAUSE THE PRODUCTS TO LEAK. DO NOT USE CLACK CONTROL VALVE PRODUCT(S) ON WATER SUPPLIES THAT CONTAIN HYDROCARBONS SUCH AS KEROSENE, BENZENE, GASOLINE, ETC.

Fitting Installation Instructions

- Installation fittings are designed to accommodate minor plumbing misalignments, but are not designed to support the weight of a system or the plumbing.
- Teflon tape must be used on the 1/4" NPT connection (when used).
- Avoid getting solvent cement or primer on the control valve, bypass valve, nut, split ring and o-ring.
- Use solvent cements and primers to connect fittings and piping in accordance with manufacturer's instructions.
- Allow solvent cements to set before installing the nut, split ring and o-ring.
- Slide nut on first, then the split ring and o-ring.
- Hand tighten the nut only.

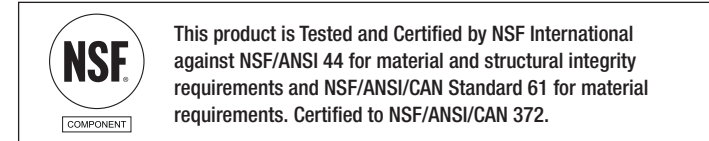

Form No. V3115-03 • 9/21/2021

Clack Order No. V3007-01

Description: WS1 Fitting 3/4" & 1" PVC Solvent 90° ASY

HYDROCARBONS SUCH AS VASELINE®, PETROLEUM JELLY, KEROSENE, BENZENE, GASOLINE, ETC., WILL DAMAGE PRODUCTS THAT CONTAIN O-RINGS OR PLASTIC COMPONENTS. EXPOSURE TO SUCH HYDROCARBONS MAY CAUSE THE PRODUCTS TO LEAK. DO NOT USE CLACK CONTROL VALVE PRODUCT(S) ON WATER SUPPLIES THAT CONTAIN HYDROCARBONS SUCH AS KEROSENE, BENZENE, GASOLINE, ETC.

Fitting Installation Instructions

- Installation fittings are designed to accommodate minor plumbing misalignments, but are not designed to support the weight of a system or the plumbing.
- Teflon tape must be used on the 1/4" NPT connection (when used).
- Avoid getting solvent cement or primer on the control valve, bypass valve, nut, split ring and o-ring.
- Use solvent cements and primers to connect fittings and piping in accordance with manufacturer's instructions.
- Allow solvent cements to set before installing the nut, split ring and o-ring.
- Slide nut on first, then the split ring and o-ring.
- Hand tighten the nut only.

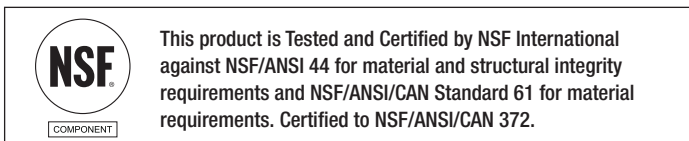

Form No. V3115-03 • 9/21/2021

Clack Order No. V3007-01

Description: WS1 Fitting 3/4" & 1" PVC Solvent 90° ASY

HYDROCARBONS SUCH AS VASELINE®, PETROLEUM JELLY, KEROSENE, BENZENE, GASOLINE, ETC., WILL DAMAGE PRODUCTS THAT CONTAIN O-RINGS OR PLASTIC COMPONENTS. EXPOSURE TO SUCH HYDROCARBONS MAY CAUSE THE PRODUCTS TO LEAK. DO NOT USE CLACK CONTROL VALVE PRODUCT(S) ON WATER SUPPLIES THAT CONTAIN HYDROCARBONS SUCH AS KEROSENE, BENZENE, GASOLINE, ETC.

Fitting Installation Instructions

- Installation fittings are designed to accommodate minor plumbing misalignments, but are not designed to support the weight of a system or the plumbing.
- Teflon tape must be used on the 1/4" NPT connection (when used).
- Avoid getting solvent cement or primer on the control valve, bypass valve, nut, split ring and o-ring.
- Use solvent cements and primers to connect fittings and piping in accordance with manufacturer's instructions.
- Allow solvent cements to set before installing the nut, split ring and o-ring.
- Slide nut on first, then the split ring and o-ring.
- Hand tighten the nut only.

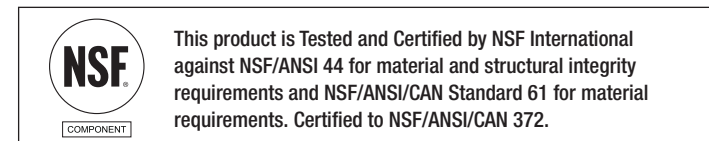

Form No. V3115-03 • 9/21/2021